

# Hygiene in drinking water reservoirs



Optimal hygienic conditions in drinking water reservoirs

- Tank flow without dead zones
- Supply air filtering
- Air gap separation in overflow line to prevent backflow
- Intelligent pipeline configuration
- Object protection

➤ Application example: Drinking water must be absolutely hygienic when fed from reservoirs into the drinking water network.

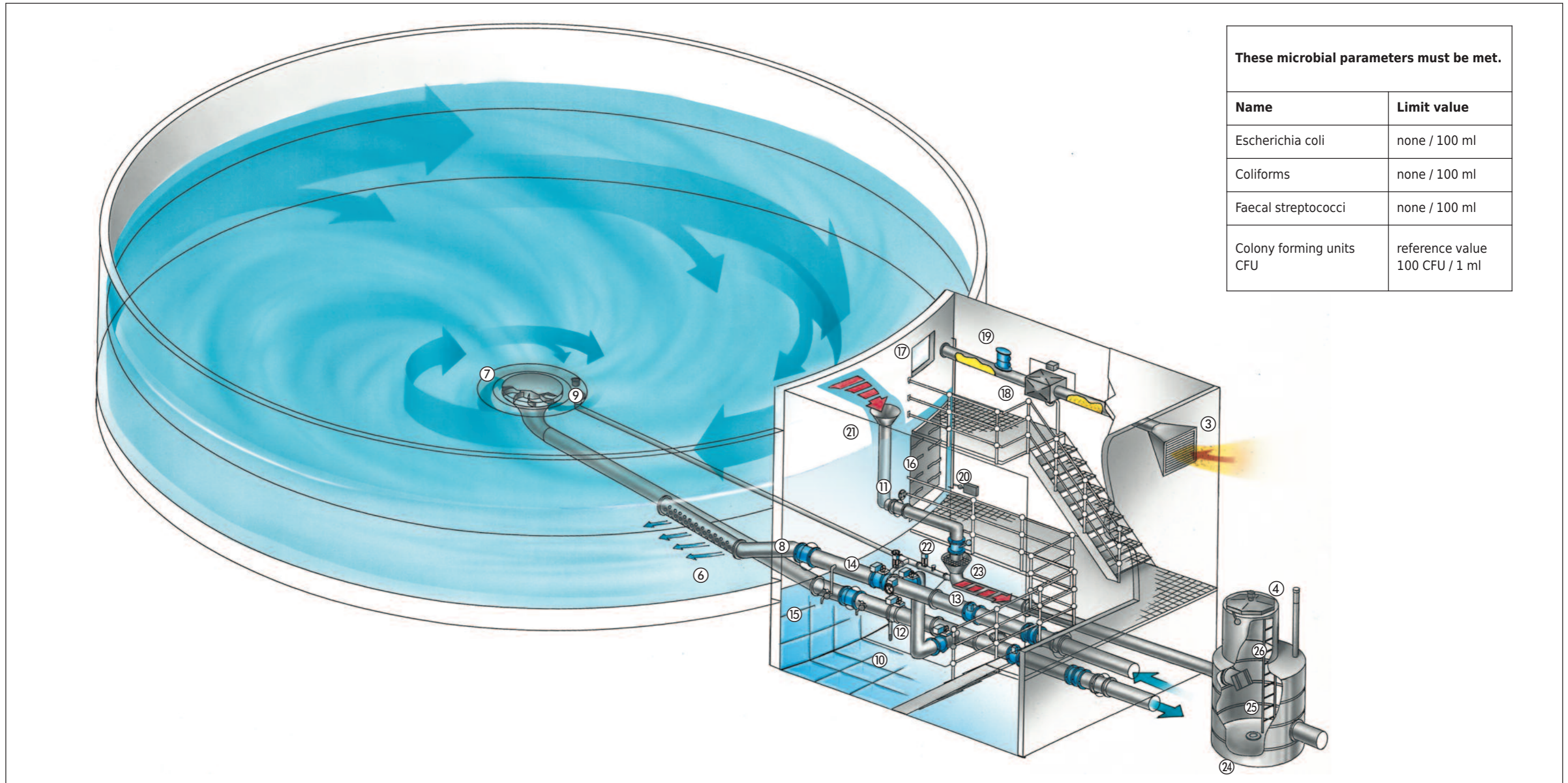

**These microbial parameters must be met.**

Name	Limit value
Escherichia coli	none / 100 ml
Coliforms	none / 100 ml
Faecal streptococci	none / 100 ml
Colony forming units CFU	reference value 100 CFU / 1 ml

**Adaption to tank configuration**

The flow system shown here is especially suitable for bigger reservoirs. In the case of smaller volumes rectangular tanks have turned out to be first choice due to lower building costs. HUBER offers suitable standard inlet and outlet solutions also for these applications.

**Outlet turbine**

The outlet turbine type HUBER NR 22 with integrated guide vanes serves as outlet construction. The turbine supports the rotary movement of the water roll and ensures equal distribution of the water over the whole circumference. Feeding and withdrawal frequently do not take place at the same time but the impulses from the feed pipe and outlet turbine guarantee stable rotary movement even under varying operational statuses. **Floating feed pipe**

The system used to feed this circular tank is the floating feed pipe type HUBER NR 27, which is permanently floating just under the water surface. Hence, the inflow energy is optimally utilized to generate a rotary movement, while near-to-the-surface water is permanently renewed and the danger of germination minimized in this area.

**Every drinking water reservoir respirates**

Huge amounts of air are sucked in as drinking water is being withdrawn. This air must be pressed out again during tank filling. The hygiene problem lies in the "breath-in" process. Depending on ambient air quality, there is a certain risk that higher amounts of dust, bacteria, viruses and germs may pass into the stored drinking water. The installation of a HUBER air filter plant reliably prevents such risks.

## ►► Drinking water

**Drinking water must be absolutely hygienic when fed from reservoirs into the drinking water network.**

### Reduced withdrawal rates cause problems

Water is our most valuable resource. Drinking water released to consumers must meet the standards set by the Drinking Water Ordinance. The consumption of drinking water in Germany has been declining in the past years. Therefore, pipeline networks and water reservoirs are partly oversized now, which prolongs water residence times from production to consumption and hence leads to hygiene problems. Optimization of water quality is necessary to counteract reduced water withdrawal rates. Operators should not miss any opportunity to minimize negative impacts during water storage.

### Drinking water is not germ-free

Drinking water is not always completely free of germs. Additional threats of biological contamination can originate from the contact of water with pipeline materials, tank surface and ambient air. Decisive factors are in this connection residence time, water temperature, nutrients content of the water and the method of treatment. And if drinking water remains within a tank for a longer time, microorganisms will multiply uncontrolled. The critical limit according to the Drinking Water Ordinance can only be estimated theoretically. Investigations of Baur and Eisenbart do not deliver any interesting evidence as obvious from the example in the above diagram.

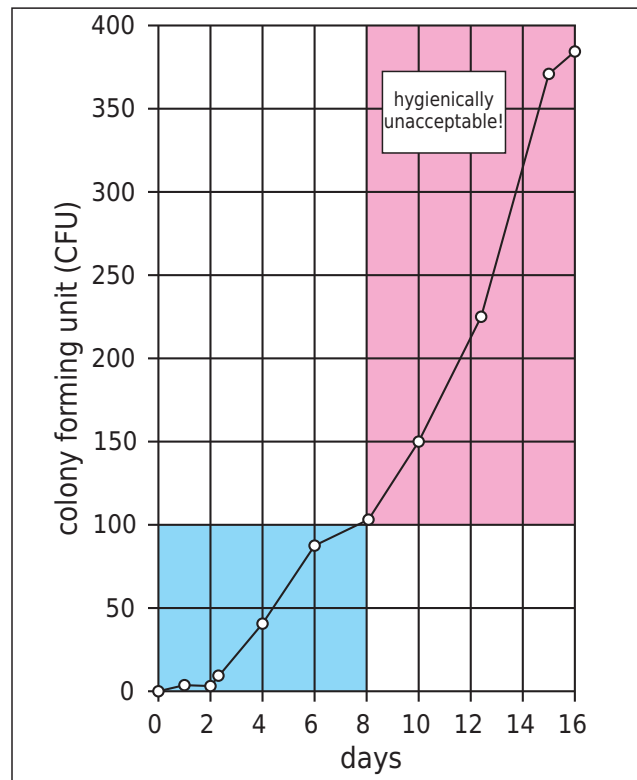

*Service life study of a reservoir. Colony count / time diagram of Baur / Eisenbart (Vedewa).*

## ►► High requirements

### an die bauliche Gestaltung und hydraulische Ausrüstung von Wasserspeicher

#### Bauliche und konstruktive Fehler

Gesundheitsämter überwachen die „Herstellung unseres wichtigsten Lebensmittels“ in regelmäßigen Abständen. Trotz umfangreicher Gestaltungshinweise in den verschiedenen Arbeitsblättern findet sich immer wieder Anlaß zur Beanstandung. Teilweise wurden die Ursachen hierfür bereits im Planungsstadium oder durch eine mangelhafte Bauausführung geschaffen. Doch auch durch geringere Wasserabgaben oder Änderungen im Rohwasser entsteht Handlungsbedarf. Die Fortschritte in der Analytik und die Erforschung bisher wenig bekannter Erreger zeigen, dass hygienisch einwandfreies Wasser am Zapfhahn nicht selbstverständlich ist.

#### Sanierungsbedarf

Viele ältere Wasserspeicher erfüllen heute nicht mehr die Regeln der Technik. Sanierungsbedarf entsteht oft

aufgrund von veralteten, hygienisch sehr bedenklicher Behältereinbauten, Schäden am Gebäude oder den Anlagen. Häufig kann man mit geringen Mitteln bereits große Effekte erzielen. Doch nur ein umfassendes Konzept ist sinnvoll. Sanierung bietet die Chance, alte Sünden auszumerzen. Schon mittelfristig verbessert sich dadurch die Wirtschaftlichkeit der Anlage.



*Wenn schon Sanierung – dann aber bitte konsequent!*

## ►► Object protection makes intruders surrender before they use violence

### Realize the danger of burglary

Cases of burglary and vandalism are reported by the police every day. Also frequently remote plants and water supply facilities are under constant threat of unauthorized manipulation. It is the operators' responsibility to ensure the drinking water does not suffer any impairment. In addition, expensive equipment, such as control and monitoring plants, need to be protected against theft or damage. The advisory body of criminal investigation departments should be consulted already in the planning stage of new plants. But also still unprotected older structures should be retrofitted.

### All-over exterior shell protection

A fence alone will not keep away burglars. And even an electrical burglar alarm system only forwards an alarm to the call point but precious time passes until the task force arrives and the burglar has time enough to cause devastation. Only the stable design of the entire exterior shell will deter uninvited guests. Even if well equipped professionals are at work, they will at least encounter

resistance until the reaction force arrives on the scene. Applicable reporting and crisis plans prescribe which measures to take. In this way, a lot of incidents could certainly have been prevented in a seminal stage.

### Security tested

Security doors, ventilation louvres and windows are necessary to ensure the exterior wall is massive. Only certified products are able to meet these high requirements. All openings and inlets should be of the same security class. HUBER security products meet the high requirements of DIN V ENV 1627-WK4 or -WK3. Beside careful manufacture and matured product design the material stainless steel ensures high mechanical strength. Due to its robustness and mechanical strength stainless steel offers maximum mechanical security against boring, sawing and grinding tools.

## ►► Exterior view of an elevated reservoir

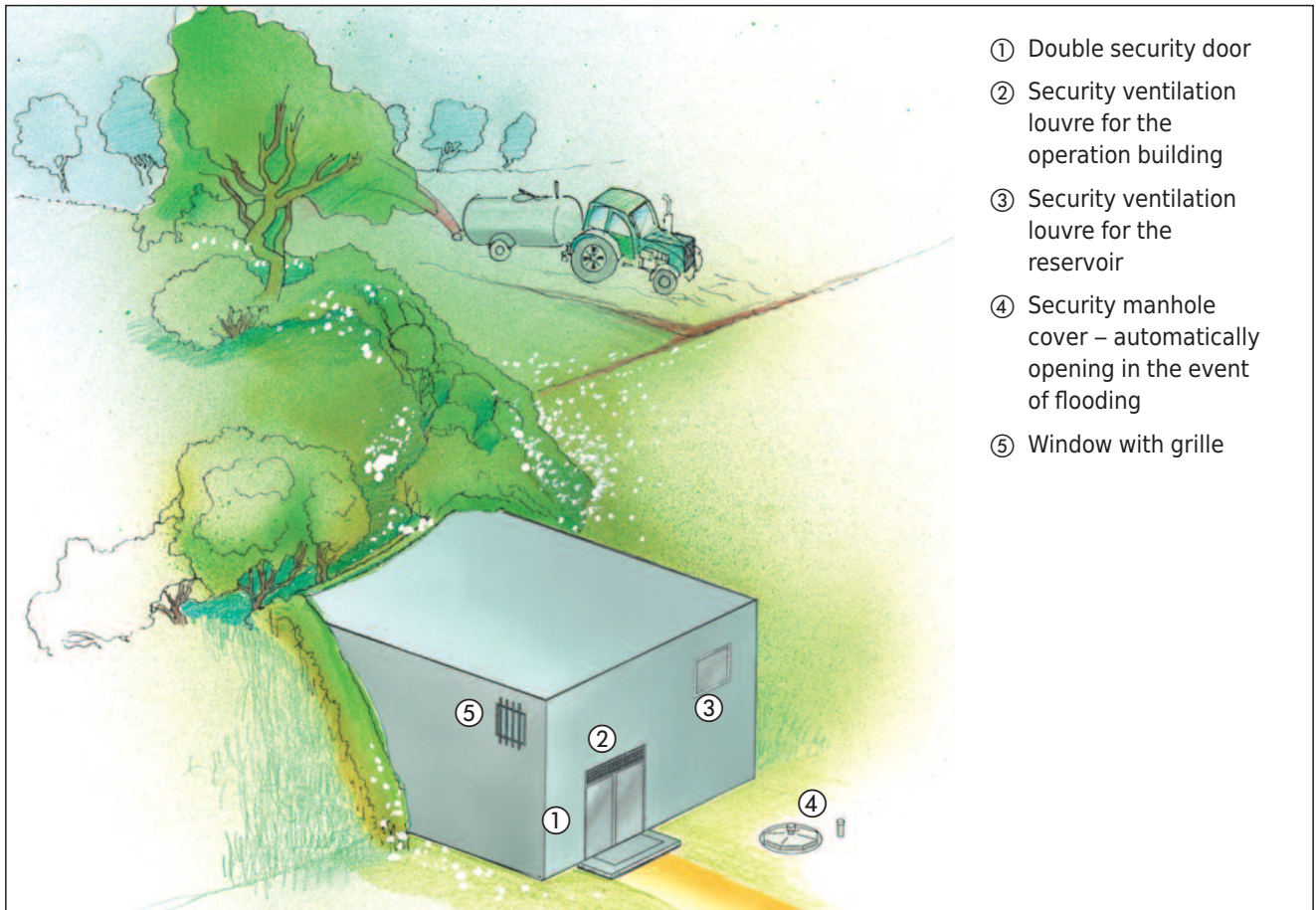

## ► Explanations – Optimal hygiene requires careful detailed solutions

### Hydraulic equipment

Feeding and withdrawal frequently do not take place at the same time but optimal interaction of the feed pipe and outlet turbine guarantees a stable rotary movement even under varying operational statuses. Moreover, also the physical air gap in the overflow line for backflow and germination prevention and sampling points ensure hygiene in operation. Not to forget maintenance! Cables and hoses can easily be laid through maintenance openings without the need to open the pressure door.

### Ventilation technology

Generally, only filtered ambient air should be allowed to pass into the water reservoir. Natural ventilation has been selected in this example, which minimizes investment and operating costs in contrast to ventilation with forced air flow.

However, the filters are charged in both directions, the danger of regermination is eliminated. The reliability of this system has been proven in long years of experience.

### Building protection and hygiene

The hydraulic equipment and ventilation technology must be designed to ensure the structure does not suffer damage whatever incident may happen. In addition, any possible hygiene risks must be prevented. In some cases the receiving water body is unable to take up the maximum volume of water discharged “in the worst case”. To avoid dangerous backwater, an automatically opening manhole cover ensures controlled release of excess water into the environment.

No.	Component	Function
3	Security louvres with coarse filter	Prevention of unauthorized access. Retention of coarse material.
4	Self-opening manhole cover	Self-opening in the event of water backup to protect the structure.
6	Floating feed pipe HUBER NR 27	Feed introduction directly below water surface to create a spiral flow.
7	Outlet turbine HUBER NR 22	Outlet turbine with guide vanes to support the creation of a spiral flow.
8	Wall entrance	Water-tight and air-tight tank feed, also suitable to be retrofitted into round tanks.
9	Drain line	To ensure complete tank depletion after cleaning work.
10	Pump sump with submersible pump	Neutralization and removal of polluted water into the sewer.
11	Wall entrance	For hoses and cables used to do cleaning work.
12	Bypass line (Reduce pressure!)	To discharge directly into the network while executing cleaning work.
13	Magnetic inductive flow meter	Flow rate measurement.
14	Shut-off valves with electric drive	Inlet and outlet control.
15	Sampling point	Hygienic representative sampling.
16	Underwater pressure door	Air-tight and water-tight inspection opening to ensure safe access to the tank for cleaning and inspection.
17	Window	Water surface inspection.
18	Air filter casing with filter inserts	Supply air cleaning with replaceable filter mats, condensate outlet and load control.
19	Air safety valve	To protect the structure.
20	Level measurement system	For correct water level indication.
21	Emergency overflow	To prevent bursting of the structure in case of operational troubles.
22	Back valve with lever and weight	Air-tight in rest position, open for water passage under flood conditions.
23	Pipeline with air gap separation	To ensure water hygiene and prevent germination caused by backflow under overflow conditions.
24	Pre-fabricated stainless steel manhole	Connection between the outlet and receiving water body as a compact pre-fabricated unit for quick and easy installation.
25	Back valve	Prevents backflow of germinated water and retains small animals like frogs, etc.
26	Safety ladder	To ensure safe entry into the manhole structure.

## ➤ Reservoir ventilation – Supply air filtering reduces hygiene risks

### There is something in the air ...

Typically, the water surface in a tank is permanently in motion. During the filling process air is streaming out, whereas during the emptying process ambient air is sucked in. In this respiration process also particles contained within the air are carried into the drinking water along with oxygen and nitrogen. Since also germs, viruses, spores and pollen are a part of such particles, the resulting hygiene problems are severe. The calculated average annual load for a 500 m<sup>3</sup> tank amounts to 21,000 mg dust or 1,680 billion germs. Even elevated reservoirs in the open countryside do not remain untroubled.

### Inefficient coarse material filters

Coarse filters retain only bigger dust particles, insects or leaves. However, specifically these pollutants causing hygiene problems are very small (smaller than 5 µm). Even fine filters are unable to achieve satisfactory separation results. Only filters for suspended particles as used successfully in operation rooms of hospitals ensure that the air is really clear. And where farmers spread slurry on their land, the only solution that helps is an additional activated charcoal filter. And what about costs? The extra costs for a filter for suspended particles are

minimal compared to that for a coarse material filter. Operators should therefore not shrink from this investment into the hygiene safety of their water reservoir.

### Complete solution of an air filter system

Air filter systems only work efficiently if neither leak air nor operating troubles can cause problems. To ensure this, the individual water chambers must close completely air-tight. HUBER offers a complete program of products that meet these new requirements: air-tight doors, windows and wall ducts. Only multiple filtering ensures efficient separation of any kind and size of particles. Depending on the specific situation and requirements, either free convection or forced ventilation is applied. As regards operational safety, the danger of implosion or bursting must be prevented. We will be happy to give advice on the optimally suitable filter technology.

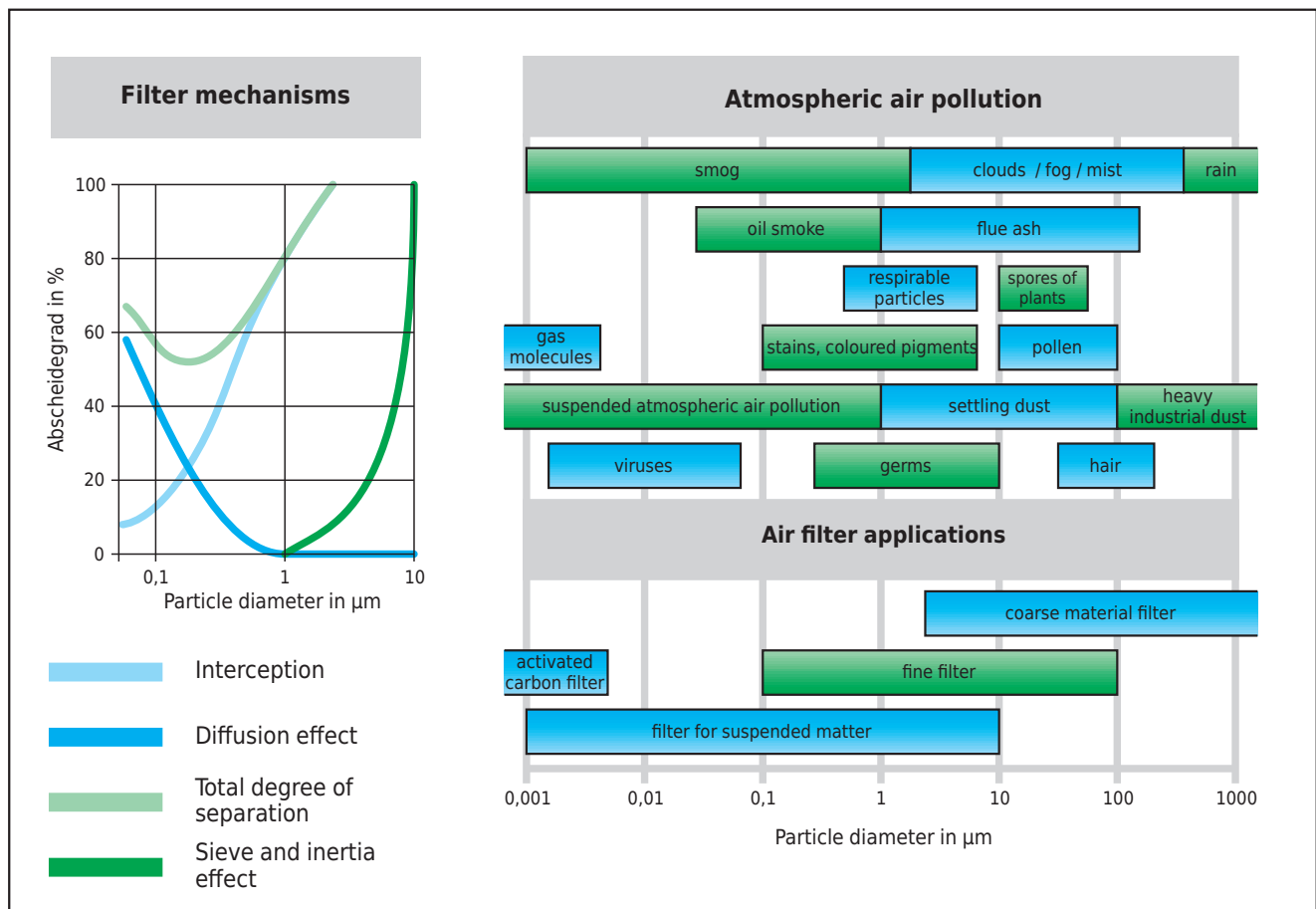

## ►► Check list for water reservoirs. Does your reservoir guarantee compliance with Drinking Water Ordinance requirements?

### Surface flow problem

Often, there is not enough movement in the surface of the water volume. Also frequently noticed thermal stratification leads to serious problems. Due to the contact with ambient air combined with increased temperature the susceptibility to germination increases. As a result, the balance of calcium carbonate and carbonic acid may be disturbed, or precipitation reactions take place. Conventional inlet constructions have a fixed feed height. Feed inlets above water level should be avoided as they do not allow for a directed tank flow. Feed inlets in the bottom area stir the water surface only insufficiently with top water level inside the tank. Only a floating feed system provides optimal conditions.

### Waiting loops in "landing approach"

Only few tanks are operated with a constant inflow and outflow. Varying water levels in buffer tanks permanently cause changing hydraulic situations but what is desired is a stable flow through the tank. At the same time, dead zones and short-circuit flows must be avoided. Drinking water holding tanks are only controllable with an intensive mixing flow, whereas a spiral countersink flow has been identified to be optimal for continuous tanks.

Similar to a landing approach to an airport the fresh feed water is circling over the "runway" (= outlet) until the OK for landing (= water discharge) is received. The HUBER outlet turbine supports this flow.

### Tank flow system as complete solution

Circular continuous tanks are optimally suited for spiral flows. Provided proper dimensioning, a stable vortex is created that continues to whirl for hours even after a feed stop. Moreover, the favourable ratio of tank surface and water volume provides optimal conditions for a low risk of germination. Similar flow conditions can however be achieved

in polygonal, square or rectangular tanks as well.

Whether new construction or reconstruction, we will be pleased to work out a solution to your specific problem, taking into consideration specific tank configuration, mode of operation, as well as inlet and outlet requirements in order to reduce problems with germination to a minimum.

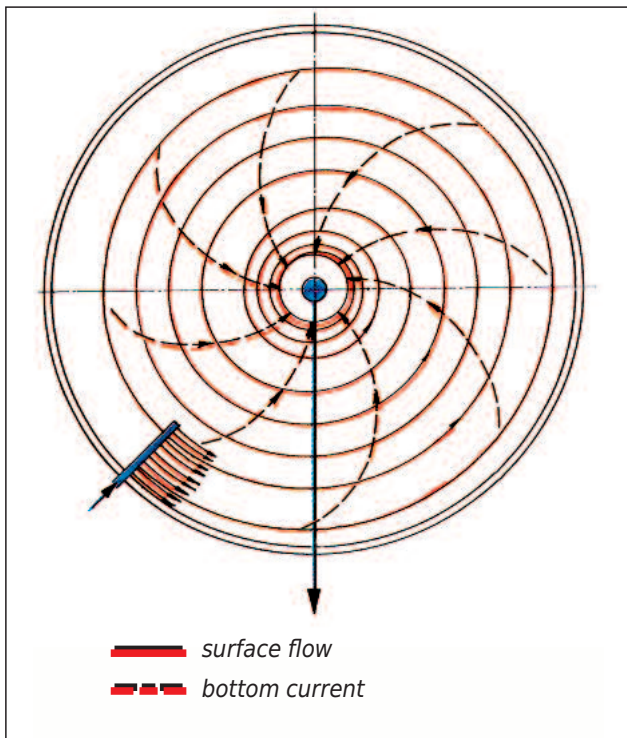

Flow in a circular tank with fan-shaped inlet and central withdrawal via a stationary outlet turbine.

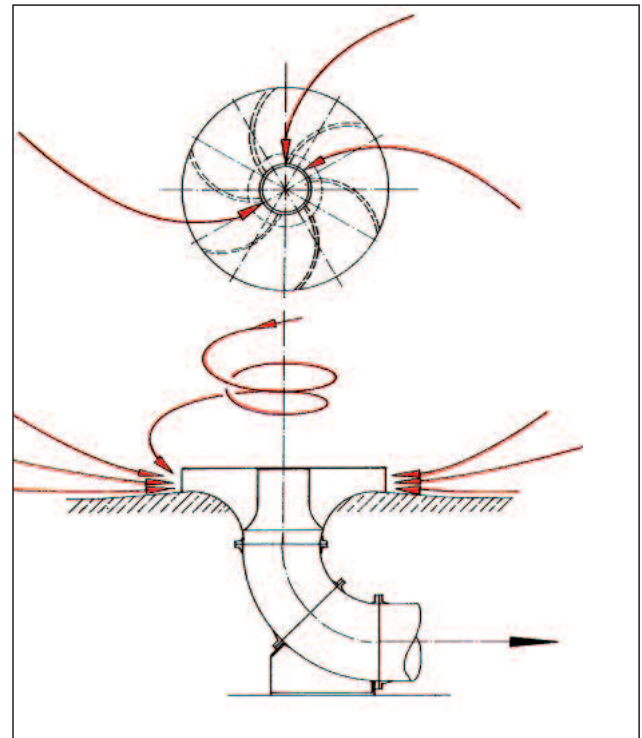

The outlet turbine supports the vortex and ensures at the same time optimal utilization of the tank volume.

## ➤➤ Check list for water reservoirs. Does your reservoir guarantee compliance with Drinking Water Ordinance requirements?

Do some of the following statements apply in your case?

### 1. Water chamber:

- Entrance directly above water level
- No possibility of inspection during operation
- Direct incidence of light
- No stairs, ladders or pressure doors
- Insufficient separation inside water chambers
- No separation of water chamber and operation building

### 2. Operation building:

- No operation building existing
- Difficult to access operation facilities
- Condensation (e. g. untight windows or doors)

### 3. Ventilation systems:

- Ventilation openings just above water surface
- Ventilation via the operation building
- Undersized ventilation systems
- No filters in ventilation systems
- Ingress of external odours
- No condensate drain in ventilation system

### 4. Tank installation:

- No separation of feed and withdrawal line
- Unfavourable mix of different waters
- No shutoff devices in feed / withdrawal line
- Wrong feed line position
- Fittings within the water chambers
- No sampling devices
- Wrong outlet line position
- No or undersized overflow
- No separation between overflow and drain line
- No inspection manhole in drain system
- Shutoff devices within the overflow line
- No or insufficient drain line
- No pipe-break protection
- Materials without KTW certificate
- No electrolytical separation

### 5. Work safety:

- No ladders, stairs, platforms, railings
- Non-compliance with applicable standards
- Materials susceptible to corrosion
- Steep and narrow transport ways
- Insufficient protective gear
- No escape ways (e.g. anti-panic lock)
- Insufficient ventilation for personnel

### 6. Protection against unauthorized access:

- Insufficiently protected doors
- No guard grilles on windows



*Would you expect to find drinking water under such a cover?*



*Dead zones and poor flow may lead to germination!*

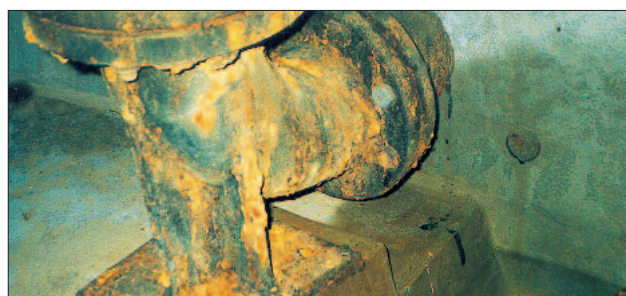

*What about safety of drinking water from such a reservoir?*

## ➤ Benefits for planners and operators from using standardized HUBER products

### Overall concept

Optimal hygiene in water reservoirs can only be ensured if an overall concept for all areas of building and plant technology is worked out and consistently implemented. Planning aids are provided in our brochures and CD ROM. In addition, our sales engineers are available for advice. Last but not least, our experienced service staff guarantee reliable installation.



*Access to water chamber*

### Standard products save costs

Based on our long years of experience we have developed a comprehensive range of standardized and stock products that we manufacture partly in series to be able to deliver quickly at favourable costs. But also stock keeping or later retrofitting are possible without problems. Individual solutions can be designed with this variety of products, but also non-standard products tailored to the customer's specific requirements are available.



*Intelligent, simple configuration of pipelines*

### Optimal hygiene with stainless steel

Stainless steel naturally possesses many positive properties as regards hygiene: smooth, hard surface; no migration, insusceptible to germination; easy to clean. And if production specifically meets the requirements of the material, then corrosion has no chance. The result is long-term safety in terms of hygiene and investments made.

**HUBER stainless steel products.**  
**Safe technology for a clean environment.**



*Hygienic, clean access area*

## HUBER SE

Industriepark Erasbach A1 · D-92334 Berching  
Phone: + 49 - 84 62 - 201 - 0 · Fax: + 49 - 84 62 - 201 - 810  
info@huber.de · Internet: www.huber.de

Subject to technical modification  
0,05 / 2 - 8.2010 - 7.2009

PG 8  
Hygiene in drinking water reservoirs