

THE ORIGINAL
ROTAMAT®!!!

ROTAMAT®

Screenings Wash Press WAP/SL



Super Launder Wash Press

- high-intensity agitation and washing in launder tank
- highly compacted and virtually odorless screenings
- volume, weight and disposal cost reduction of up to 85 %
- feeding through a launder channel or directly from a screen



Function

The WAP/SL operates in a batch mode. Screenings either drop into the launder tank directly from a screen or conveyor, or they are flushed into the tank through a launder channel. After a batch of screenings has been fed, the tank is filled up with wash water and agitated for an adjustable period by means of an impeller. The fecal matter is loosened and removed from the screenings by high turbulence and shear.

After the washing cycle has been finished, an automatic valve opens and the wash water drains through perforations in the trough. It returns, together with the fecal matter, to the wastewater flow. A screw in the trough conveys the screenings towards the mouth of a tube whereby they are, as an additional option, rinsed with spray water. The screw pushes the screenings through the pressure zone where they are compressed, dewatered and compacted before they are finally discharged through the discharge pipe into a dumpster or bagger.

Feeding through a launder channel

The screenings drop from the screen or conveyor into a launder channel. Screened wastewater or process water flushes the screenings through the channel into the launder tank of the washpress. The flush water also serves as wash water in the launder tank.

Feeding directly from a screen or conveyor

The screenings drop from the screen or conveyor into the launder tank. Screened wastewater or process water is directly introduced into the tank as wash water.



High turbulence in the launder tank during impeller operation

Benefits

- High-intensity washing in launder tank
- Compaction up to 50 % DS
- Volume, weight and disposal cost reduction by up to 85 %
- Screenings processing capacity of up to 210 ft³/hr (6 m³/h)
- All fecal matter is returned to the wastewater and available for denitrification
- Screen wastewater or process water can be used as wash water
- Sturdy design
- All structural parts, including the screw, are made of stainless steel to prevent electro-chemical corrosion
- Pickled in an acid bath for perfect finishing and corrosion protection
- Fast payback due to great transportation and disposal cost savings

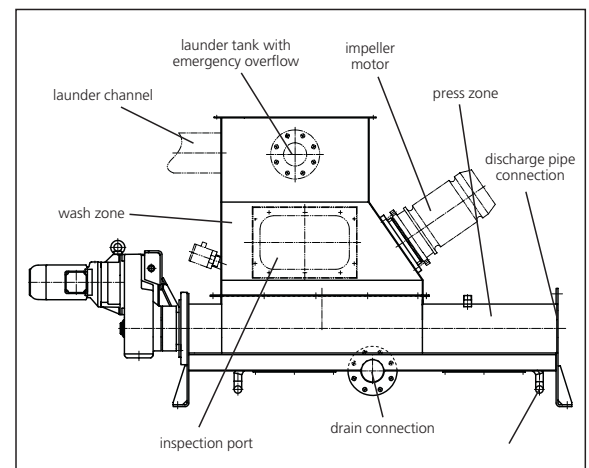

Well washed and virtually odorless screenings from a WAP/SL, compacted to 50 % DS

HUBER TECHNOLOGY, Inc.

9805 NorthCross Center Ct.
Suite H
Huntersville, NC 28078

Phone: (704) 949 - 1010

Fax: (704) 949 - 1020

huber@hhusa.net

<http://www.huber-technology.com>

Subject to technical modification

ROTAMAT®

Screenings Wash
Press WAP/SL